

## FROMM FV300-90 Semi Automatic Orbital Wrapping Machine

FROMM's FV300-90 orbital wrapping machine is perfect for wrapping long products (min. 350mm) through it's 900mm diameter ring. Ideal for pipes, tubes or rods.

Extremely low maintenance, the FROMM FV range is exceptionally easy to install & operate - Plug and play, no fuss.

Backed up by FROMM Packaging Australia, rent or purchase options, the FV300-90 delivers for the Australian industry. All equipment is supported by our on-site mobile service team and spare parts are readily available.

### Orbital Wrapping Film

For optimal wrapping efficiency we recommend our range of Orbital wrapping film. Talk to our friendly staff today!



### ★ Features

- Double reel film dispensers
- Adjustable speed (RPM)
- Mechanical film break
- Manual start by foot switch
- Easy to use
- Infeed and outfeed conveyors available
- Top pressers available to hold load in wrapping cycle

### + Benefits

- High speed throughput
- Easily accommodates different products
- Plug and play technology
- Fast roll changes
- Lots of optional extras
- FROMM 2 year warranty

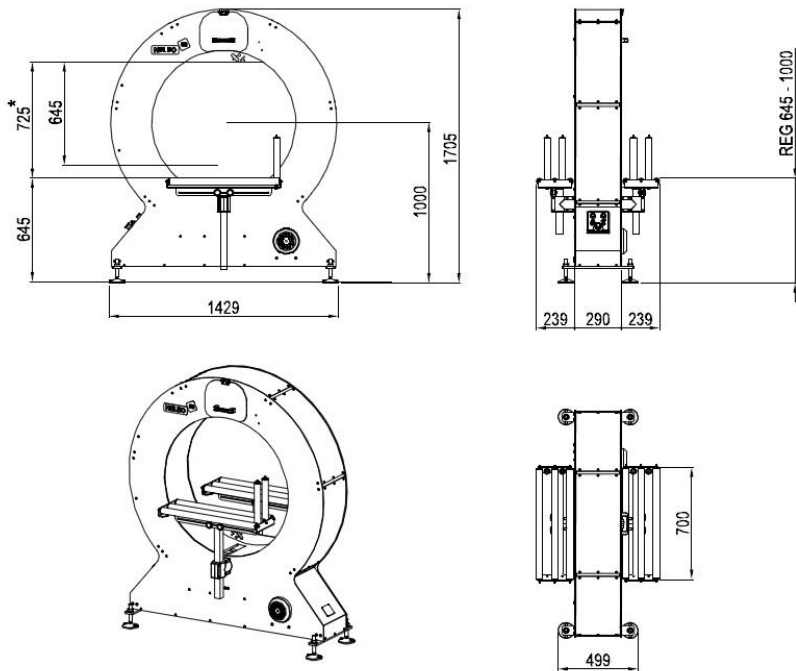

## ★ Technical Specifications

### Ring:

Diameter (mm):	900
Max. rotating speed (RPM):	90

### Product Size:

Max. product size (mm):	H 640, W 890
Min. product size (mm):	H 200, W 200
Max. product length:	No limit
Min. product length (mm):	350 or 250 with short products bridge
Max. weight (kg)	Dependent on conveyors

### Film Specification:

Width (mm):	100, 166
Thickness (um):	17 - 30

### Power Supply:

240V, Single Phase, 50 Hz
Air supply needed:

6 bars

### Power Consumption:

Power consumption approx. (kW):
---------------------------------

0.31

### Air Consumption:

5L / cycle
------------

### Machine Options:

- Conveyors - infeed and outfeed
- Automatic film cut and clamp
- Top pressers
- Bridge for short products
- Safety system

**FROMM** | PACKAGING  
AUSTRALIA

Australia Wide

T 1800 023 890

E info@fromm-pack.com.au

W www.fromm-pack.com.au