

# FSM-NEO Automatic Strapping Machine

## OPERATION MANUAL



<b>Machine</b>	Automatic Strapping Machine
<b>Model</b>	FSM-NEO
<b>Date</b>	April 2018
<b>Issue</b>	FPA001

# CONTENTS

1. General Information	1
1.1 Notice of Installation	1
1.2 Notice of Operation	1
2. Safety Instructions	2
2.1 Before Operating	2
2.2 During Operation	2
2.3 After Operation	2
2.4 Safety Hazards	3
2.5 Maintenance	4
2.6 Storage	4
2.7 Other Reminders	4
2.8 Attention	4
2.9 Emergency Procedure	4
3. Machine Structure	5
4. General Safety Remarks	6
4.1 Basic Operation	6
4.2 Basic Safety Precautions	6
4.3 Safety Instructions Governing Specific Operational Phases	6
4.4 Warning of Electrical Dangers	7
4.5 Grounding Instructions shall include the following	7
5. Machine Information	8
5.1 Technical Data	8
5.2 Operating Elements	9
5.3 Loading the Strap	14
6. Operating the machine	15
6.1 Switching the Machine On	15
6.2 Threading the Strap	15
7. Maintenance	16
8. Troubleshooting	17
8.1 Suggested Maintenance	17
8.2 Warranty Periods	17
8.3 Fromm Service Technicians	17
8.4 Possible troubleshooting causes and remedies	18
9. Contact Fromm Packaging	21

## **1. GENERAL INFORMATION**

Congratulations on the purchase of your Fromm Strapping Machine. We trust you will have many years of packaging efficiency.

*Before proceeding with the operation or installation of your new machine please read this manual thoroughly and gain a full understanding of the requirements, features and operation of your new machine.*

### **1.1 NOTE OF INSTALLATION**

To ensure your machine operates in a safe manner please review the following requirements:

1. Machine standard power is 240V (+- 10%)
2. Machine standard power Hertz is 50Hz. (+- 2%)
3. Machine can operate in temperatures between 5°C - 45°C
4. The position where you place the machine must be flat and have no vibrating machines around the wrapping machine.
5. Please ensure you download and read our Install Guide before attempting it yourself.

### **1.2 NOTICE OF OPERATION**

Before you start using the wrapping machine, please review the following conditions:

1. Before operating, please read the machine operational manual carefully.
2. Make sure there is no object put on the power cable.
3. Make sure there is no object put on the upper elevator unit.
4. Avoid any damp object or water around the electric parts.
5. Do not stand on or across from the machine during operation.
6. When a problem does occur, please check the troubleshooting section for more information and advice.

## 2. SAFETY INSTRUCTIONS

### 2.1 Before Operating

1. Read the instruction manual.
2. Wear eye protection and safety gloves before operating this machine.

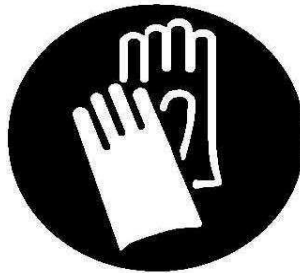
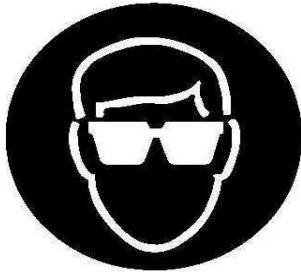

3. Eye protection must be worn
4. Safety gloves must be worn
5. Ear-protector must be worn
6. Verify that the power line voltage is correct.
7. The machine must be properly grounded to avoid a shock hazard. All wiring must be in accordance with local wiring standards.
8. The strapping machine can only be operated with polypropylene (P.P.) strapping and polyester (PET) strapping; do not use polyethylene (PE) cord strap.

### 2.2 During Operation

1. The weight of the package cannot exceed 30 kg.
2. The size of the package should not be less than 55mm (width) × 5mm (height).
3. Check if the machine emits any smokes or unusual sound when it is running.
4. Keep away from the inside of the arch while the machine is operating; do not put your hands or body into the arch when the machine is running.

### 2.3 After Operation

1. Remove dust and dirt from the unit; pay particular attention to the interior of the arch.
2. Turn off the power when the machine is not in use.

## 2.4 Safety Hazards



The main switch must be kept accessible. It also functions as Emergency Stop switch.



The sealing of the strap is executed by heating up the welding plate. Touching it may cause burns.



Machine must be disconnected from power supply prior to opening the machine interior and prior to beginning any maintenance or repair work (pull out mains plug).



Never remove safety equipment or disable safety devices by making changes at the machine.



Run cables safely (e.g. in cable ducts) so that they cannot cause tripping over.



Caution: components are moving during operation! Keep out of reach of working range of press bar and strap arch!

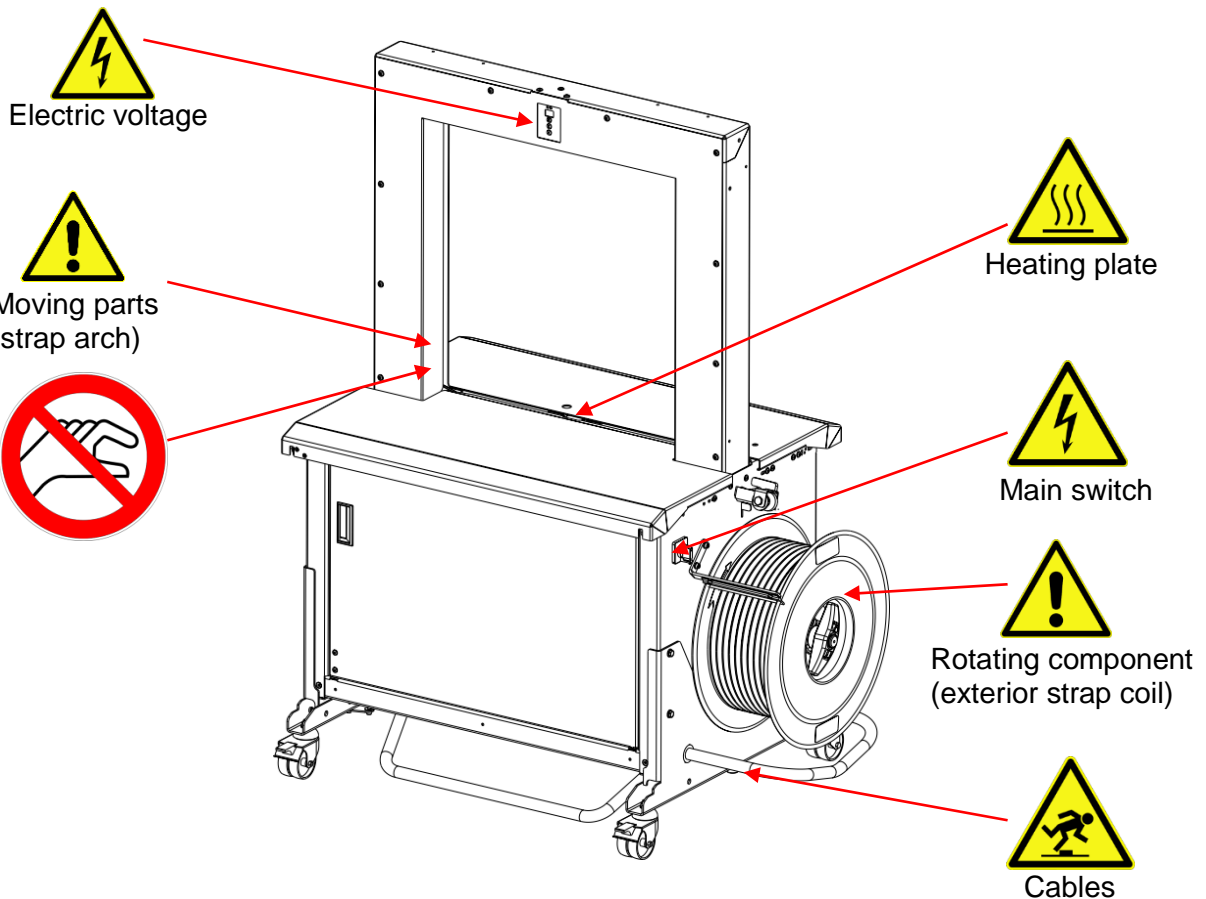

## 2.5 Maintenance

1. Turn off the power before removing either of the top covers.
2. The heater tongue is very hot; do not touch it.

## 2.6 Storage

1. The store room must be dry.
2. Do not expose the machine to extreme cold or heat environment.
3. Place the machine on an even floor in order to avoid any distortion.

## 2.7 Other Reminders

1. An operation manual must remain attached to the machine at all times.
2. Do not alter the equipment or circuitry unless authorized to do so by the manufacturer.

## 2.8 Attention

When the machine arrives in your warehouse, you need to use a forklift to take it off from the pallet.

## 2.9 Emergency Procedure

In case of an emergency, shut the machine down immediately by turning the main switch from position "1" to "0".

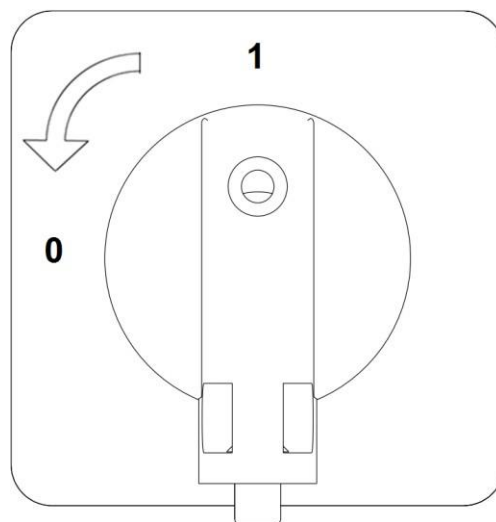

### 3. MACHINE STRUCTURE

- 1 Main switch
- 2 Operating terminal
- 3 Foot switch
- 4 Strap arch
- 5 Electric power connection
- 6 Table tops
- 7 Functional modules
- 8 Strap coil
- 9 Sealing head
- 10 Strap drive
- 11 Strap reservoir
- 12 Reservoir drive
- 13 Electric cabinet
- 14 Suction unit
- 15 Strap arch cover
- 16 Frame with moving carrier
- 17 Safety door
- 18 Back panel

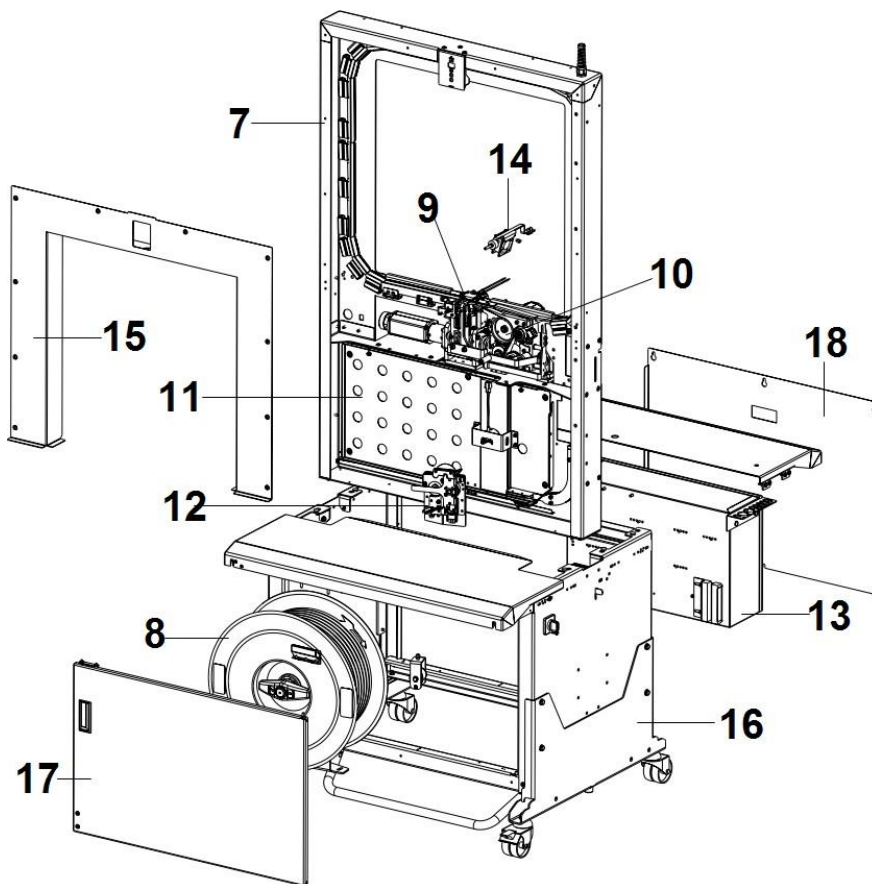
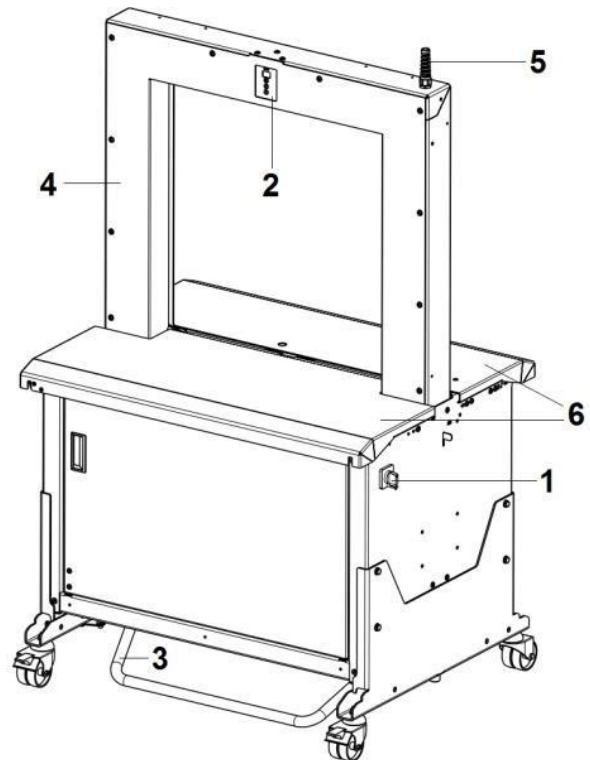

## **4. GENERAL SAFETY REMARKS**

### **4.1 Basic Operation**

The machine is only to be operated when in good running condition and in accordance with the instructions provided in the operation manual. Operators must be trained in proper operation and safety of the equipment.

The machine may only be operated in accordance with its designated use.

### **4.2 Basic Safety Precautions**

In addition to the instructions for operation, the user is to be instructed in all generally applicable legal or mandatory regulations relevant to safety or the environment. Long hair, loose-fitting garments, or jewelry can be a safety hazard. These items must be secured prior to equipment operation.

Use protective equipment whenever appropriate or when required by law.

Carefully observe all safety instructions and warnings attached to the machine.

Keep safety labels clean and legible. People that are being trained to operate or service the equipment must be supervised by experienced personnel.

Any electrical work performed on the equipment must be conducted by a skilled electrician or under the supervision of a skilled electrician. All work must observe good electrical engineering practice and follow safety rules and local wiring standards.

### **4.3 Safety Instructions Governing Specific Operational Phases**

Avoid unsafe operation of the equipment.

The machine is only to be operated when it is in good running order. Only operate the equipment in a safe manner; all protective and safety devices must be in place and fully functional. This includes removable safety devices, emergency shut-off equipment, noise-protection devices and exhaust fans.

The machine is to be checked for damage and defects at least once each work shift. Any changes, including the working behavior of the machine, are to be reported immediately. If necessary, the machine is to be stopped and locked-out immediately.

In case of a malfunction, the strapping machine is to be immediately stopped and locked-out until the fault has been eliminated.

Before starting the strapping machine, make sure that the area is clear and safe. Operating personnel need to be briefed before executing special operations and maintenance work; this work needs to be done with the proper supervision.

Always check and tighten connections after maintenance or repair.

After completing maintenance or repair, all safety devices must be replaced and checked for functionality before operating the equipment.

To minimise the environmental impact, all consumables and replaced parts must be disposed of safely.

Before starting the machine, check that the accessories have been stowed away safely. Avoid operating the machine in a fashion that could upset its stability.



## **4.4 Warning of Electrical Dangers**

### **Electrical Energy**

Immediately remove power to the machine in case of trouble in the electrical system. Replace a fuse with one with the same style and ratings; pay particular attention to matching the specified current.

Any electrical work performed on the equipment must be conducted by a skilled electrician or under the supervision of a skilled electrician. All work must observe good electrical engineering practice and follow safety rules and local wiring standards.

Inspect the electrical equipment of the machine at regular intervals. Tighten any loose connections. Check wiring for scorch marks; replace scorched wiring and determine and correct the reason for the overheating.

When working on live equipment, ensure that a second person is available to cut power in case of an emergency. When appropriate, secure the working area with safety tape and a warning sign. Use insulated tools for electrical work.

Before working on high-voltage assemblies, turn off the power supply. Carefully discharge the supply cable and short-circuit any energy-storage components such as capacitors.

If the equipment was moved, carefully refit and refasten all parts removed for transport before reapplying power.

Before moving the machine, remember to disconnect the power cable.

## **4.5 Grounding Instructions Shall Include the Following**

This product must be grounded. In the event of an electrical short circuit, grounding reduces the risk of electric shock. This product is equipped with a cord that has a grounding wire and an appropriate grounding plug. The plug must be plugged into an outlet that is properly installed and grounded in accordance with all local codes and ordinances.

If repair or replacement of the cord or plug is necessary, connect the ground wire to the ground terminal of the plug. The wire with green insulation (with or without yellow stripes) is the grounding wire.

Check with a qualified electrician or service person if the grounding instructions are not clear or if in doubt about the proper grounding of the machine. Do not modify the plug provided; if it will not fit the power outlet, have the proper outlet installed by a qualified electrician.

## 5. MACHINE INFORMATION

### 5.1 Technical Data

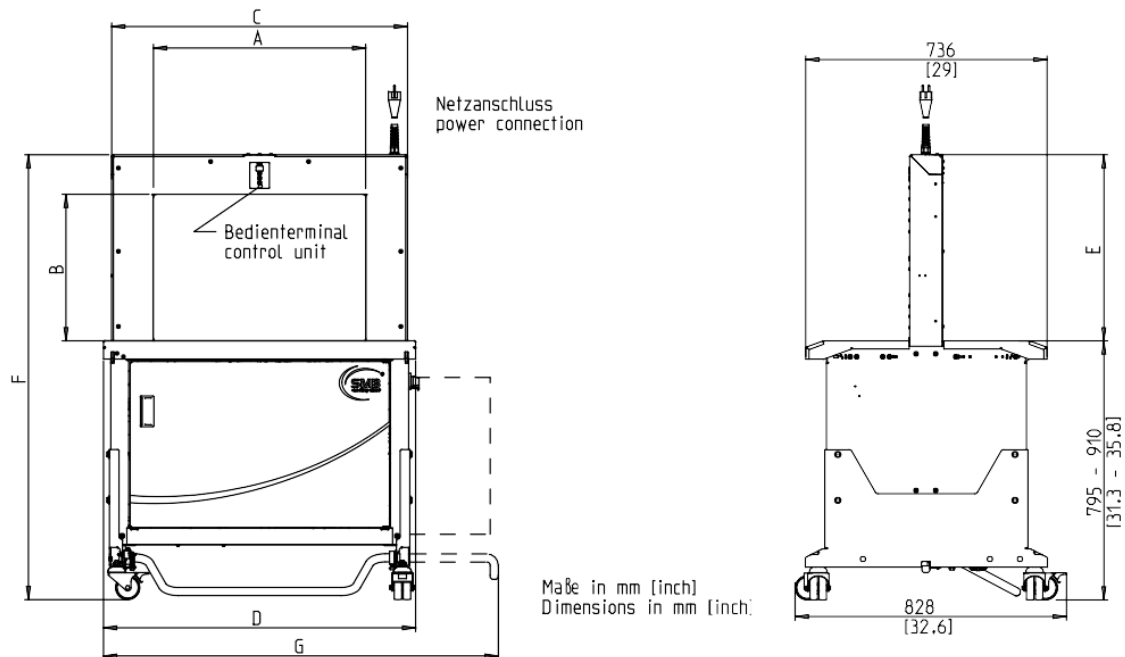

Arch Size (WxH)		600x400	600x600
Sealing Head Centered		Yes	Yes
Total Length	D	956	956
Total Height	F	1365-1485	1565-1685
Inner width (arch)	A	650	650
Arch width	C	910	910
Inner Height	B	448	648
Arch height	E	573	773
Table height with casters		795-910	795-910
Weight in kg		180	185
Max bundle width		600	600
Max bundle height		400	600

Sealing Method	Heat
Strap Width	5-12mm
Strap Thickness	0.4-0.65mm
Strap Roll Diameter	200mm
Joint Strength	Approx. 80%
Throughput	55 cycles / min
Tension	Max. 325N
Electrical Connection	AC 240V, 50/60Hz, 1 Phase
Ambient Temp	5-45°C

## 5.2 Operating Elements

Main switch, operating terminal and foot switch are located at the machine.

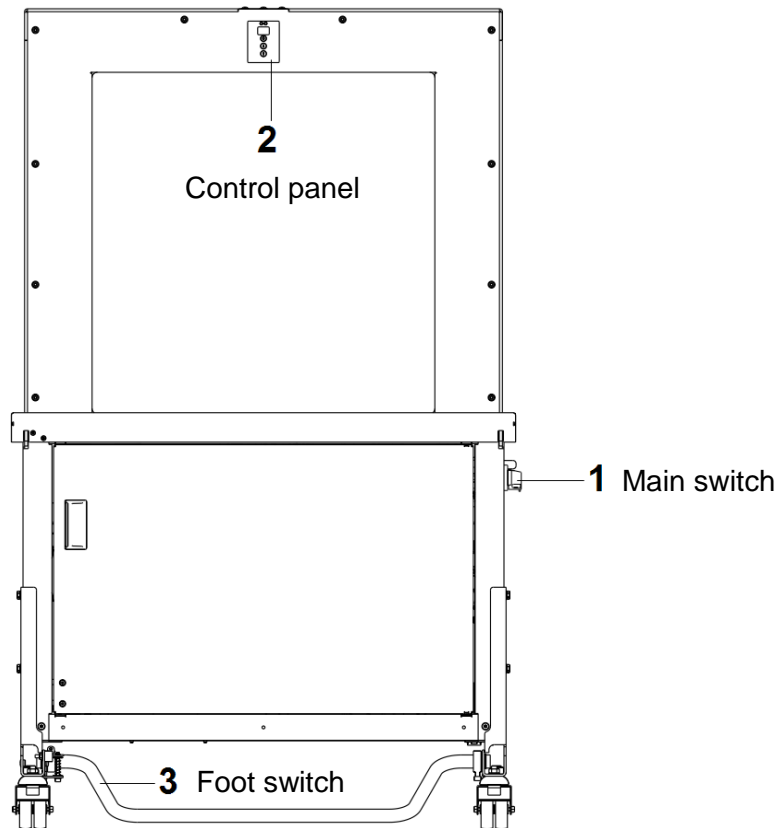

### 5.2.1 Main Switch

Start machine operation by turning the main switch to position "1". In case of an emergency the main switch must be turned back to position "0".

## 5.2.2 Control Panel

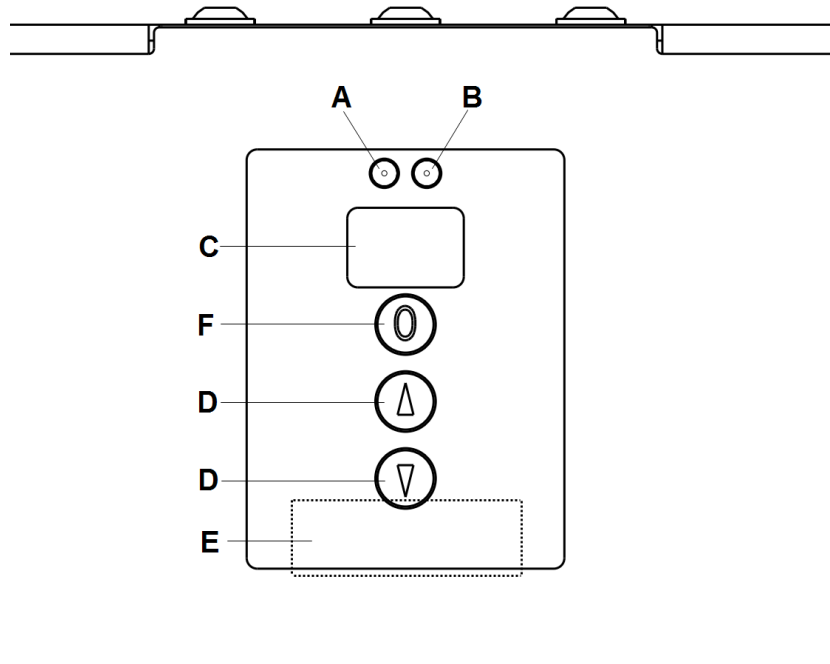

### A. & B. LEDs

The three-coloured LED (A) indicates operating conditions of the machine:

Red	Failure
Flashing Red	Heating up time
Green	Ready for operation
Flashing Green	Strap cycle in progress
Flashing red/green alternating	Signal at menu inhibiting input is received; all potential setting possibilities are available
Orange	Supervisor mode
Flashing orange	Output force mode active

If one-coloured LED (B) lights up yellow, the strap coil is running low (strap coil detection is an optional feature).

### C. Display

Display functions to indicate several activated operating features and messages:

1,2,3,4,5,6,7,8,9	Strap tensioning values
U	Operation with ultrasonic sensor
0	Soft tensioning mode
C3 – CH	Messages (see also table 3)

### D. Arrow Buttons

Use the two arrow buttons to increase or reduce strap tensioning force, ranging between 1 and 9.

## E. Ultrasonic sensor

Ultrasonic sensor is a separate module which is available as extra equipment. Bundle height detection via ultrasonic is activated using the arrow buttons, setting the display to indicate "U". With this function activated, a high bundle is strapped applying high strap tensioning; a low bundle is strapped using low strap tensioning.

## F. Soft tensioning button

When soft tensioning button is activated, strap tensioning switches off. In soft tensioning mode this button lights up in green. The segmented display indicates the value "0". Soft tensioning cannot be adjusted using the arrow buttons. Press soft tensioning button again to deactivate this function. The machine returns to indication of previous tensioning value.

### 5.2.2.1 Supervisor Menu Level

The display shows "E ." after pressing both arrow buttons for two seconds. It is possible to switch to the display menu "A-" by pressing the soft tensioning button for 3 seconds within this time.

The different menu levels can be called by pressing the arrow buttons starting from menu "A-". "A-", "d-" etc. represent the first menu level and are closed by choosing "nn".

"A0", "d0" etc. represent the second menu level and are closed by choosing "An", "dn" etc. After this, the strapping mode is available again.

Table 1 shows all settable parameters.

**Table 1: Menu parameters with setting ranges and factors**

Parameter	Name	Description	Setting Range	Factor
A0	Customer strap counter (resettable)	Can be used as a daily counter	-	-
A6	Reset customer strap counter	Resets A0	0 - 1	-
A8	Strap counter – not resettable	-	-	-
AP	Display of program number	Software version of machine	-	-
d7	Maximum limit value strap tensioning	Back tensioning force at value "9"	15 - 32	10N
d8	Minimum limit value strap tensioning	Back tensioning force at value "3"	1 - "d7-1"	10N
H0	Opening time of pressure plate at back tension "0"	-	0 - 99	100ms
H1	Opening time of pressure plate at back tension "1"	-	0 - 99	100ms
H2	Opening time of pressure plate at back tension "2" - "9"	-	0 - 99	100ms
H4	Temperature of welding plate	Temperature of sealing process	20-70	10°C
P0	Delay table top switch	Time duration between covering of table top switch and start of strapping	1 - 99	10ms
P1	Delay multiple strap	Time between two straps	1 - 99	10ms
P2	Table switch (0=Off, 1=On, 2=multiple strap)	Activation (single or multiple) or deactivation of table switch	0 - 2	-

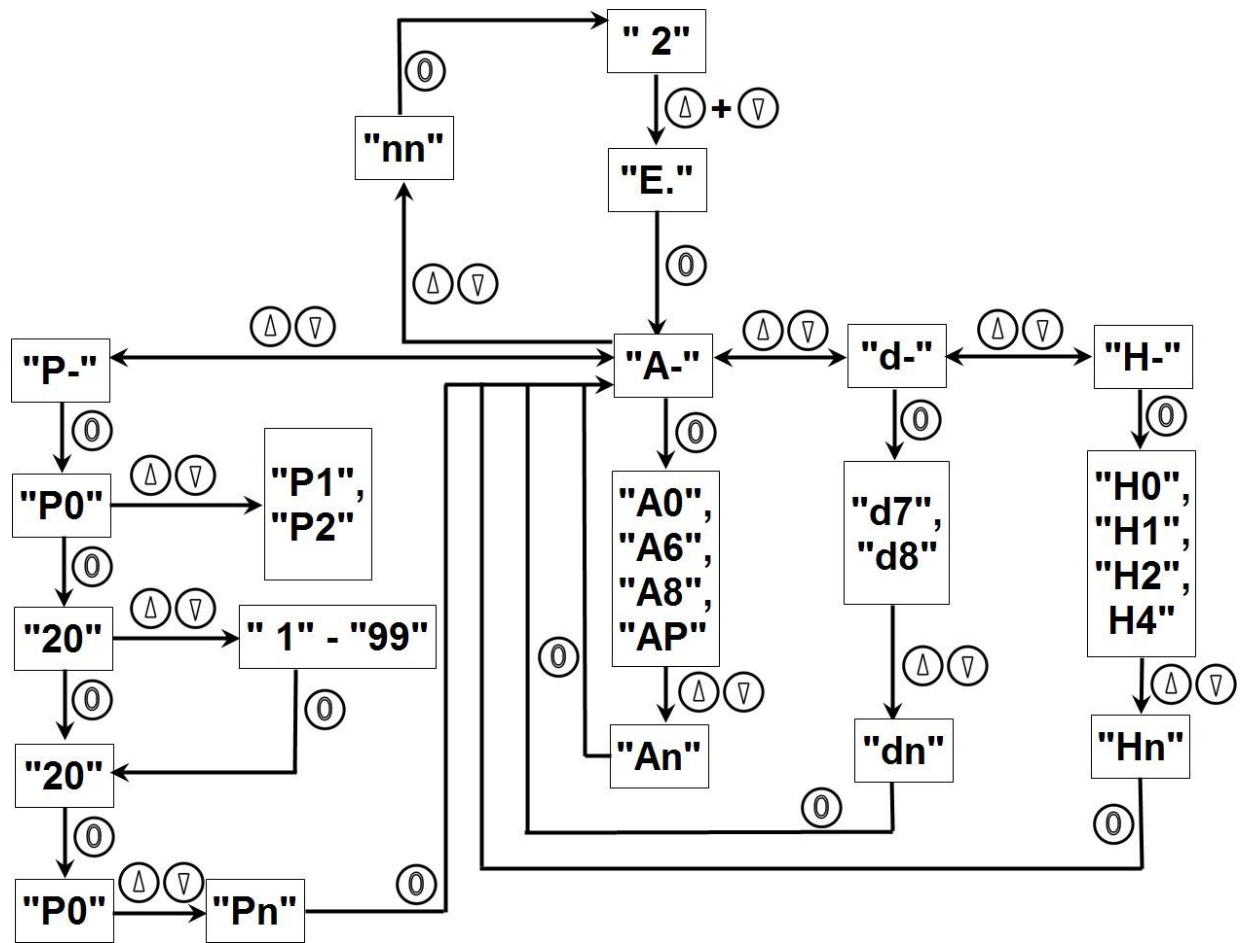

Fig. 1: Menu of control unit. Strapping mode is shown with back tensioning value 2. To switch from one menu item to another, press the shown buttons. Menu level "P-" is shown in detail. In this example, the value for the delay of the table top switch "P0" is adjusted to "20", which corresponds to a time value of 200 ms.

### 5.2.2.2 Display Menu A

#### Total strap counter A8

Menu item "A8" (total strap counter) is called by pressing the soft tensioning button. The value of the total strap counter is shown for 30 seconds by pressing the soft tensioning button. After this or by pressing the soft tensioning button again, menu item "A8" is shown again.

The 8 digits of the value are shown in succession. A value of 12,345,678 would be shown like this:

- „- -“ -> start
- „12.“ -> 1st and 2nd digit and point
- „34“ -> 3rd and 4th digit
- „5.6“ -> 5th digit and point and 6th digit
- „78“ -> 7th and 8th digit

After this, the display is repeated and starts again with "- -". The counter "A8" cannot be reset.

#### Customer strap counter A0

The customer strap counter can be shown analogue to "A8". It can be reset by setting parameter "A6" to "1".

### **Program version “AP”**

The program version is shown by selecting the menu item "AP". The program version is shown for 30 seconds by pressing the soft tensioning button.

The 8-digit number is displayed in succession.

The version P01-01 of the SMB NEO would be shown like this:

„- -,-> Start

„P0“ -> 1st and 2nd character

„1-“ -> 3rd character and hyphen

„01“ -> 4th and 5th character

„NE“ -> for SMB NEO

After this, the display is repeated and starts again with "- -".

### **5.2.2.3 Limits of Back Tensioning in Menu “D-”**

The maximum and the minimum limit of the back tension can be adjusted at parameters "d7" and "d8".

### **5.2.2.4 Settings of Welding Head in Menu “H-”**

The time settings for the duration of the opening time of the pressure plate as a function of the back tensioning ("H0", "H1", "H2") as well as the temperature of the welding plate ("H4") can be adjusted in menu "H-".

### **5.2.2.5 Parameter Menu “P-”**

The values of the table top switch can be adjusted in menu "P-".

The delay of the table top switch "P0" can be decreased or increased by pressing the arrow buttons. The value changes faster by pressing the button for a longer time.

### **5.2.3 Foot Switch**

The foot switch can be used to trip a strap cycle. When the foot switch is actuated only once shortly, just one strap cycle is triggered. When the foot switch is pressed continuously, strap cycles are tripped continuously until the switch is released.

In strap threading mode, the foot switch is used to start the strap threading process after the strap has been inserted into the reservoir drive.

### 5.3 Loading the Strap

- Open safety door (E).
- Remove coil disk (C).
- Slide strap coil (A) onto carrier (B). The cardboard discs must stay on the coil.
- The strap coil must rotate clockwise when the strap is pulled off (see arrow on coil disk C).
- Place coil disk (C) on axle of the coil carrier and tighten using tensioning nut (D) by hand until the coil plates rest on the cardboard disks. The coil plates must not stick up!
- Remove safety strips and labels.

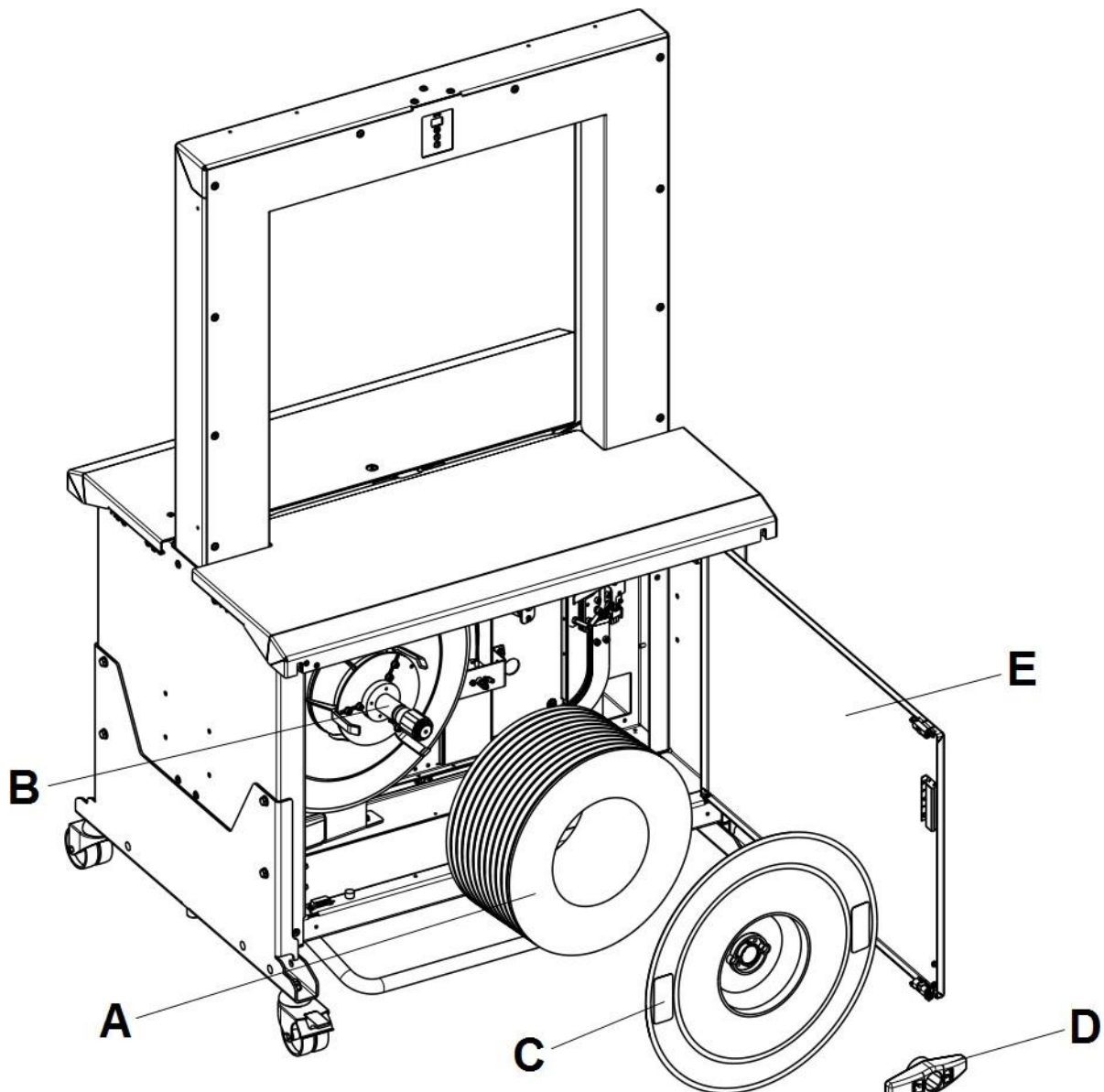



## 6. OPERATING THE MACHINE

### 6.1 Switching the Machine On

- Turn main switch to position "1".
- After switching on the heater plate starts heating up (approx. 30 sec.)
- Wait until LED A at the operating terminal indicates continuous green light.

### 6.2 Threading the Strap

- Turn main switch (A) to position "1". The display indicates "i5" (coil empty / ready for threading)
- Press foot switch (B), coil brake starts cycling, reservoir drive starts running
- Door (E) open (all drives except the reservoir motor will be out of function).
- Put the strap so far over the roller (G) into the strap track (H), until the strap will be gripped by the driven roller of the strap drive.
- By detecting the strap, the proximity switch B66 will be free and the strap drive switched off.
- Close door (E) and table top. The display will show "i3" (Start button / foot switch)
- Press foot switch (B) to start automatic threading.

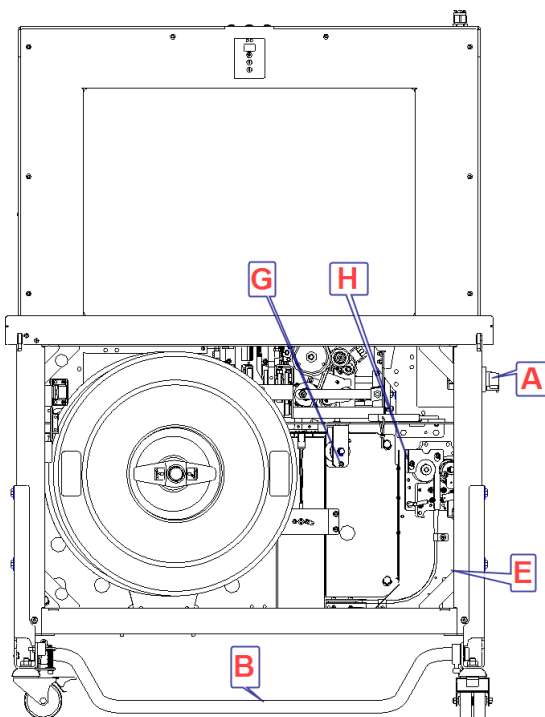

## 7. MAINTENANCE

### Warning:

**Before starting any maintenance or repairs to the machine, set the Main Power Switch to "O" (OFF). Wait about 5 minutes for cooling down the heater element to avoid burns.**

### 7.1 Cleaning

#### Weekly:

- Clean machine interior, especially: Heater plate assembly
- Strap guide and strap track Strap threading assembly Strap reservoir
- Pressure plate switch
- Clean all light sensors using a piece of cloth and check function.
- Check function of the fan. ATTENTION: Do not blow air into the fan.
- Check that reservoir lever is easy moving.
- Check that deflection roller is easy moving.
- Check that both tension rollers, feed roller and pressure roller in strap drive are easy moving.
- Check that the two rollers in the reservoir drive are easy moving.
- Execute test-strapping on several bundles, paying attention to any audible or visible failures, check function.



ATTENTION: When blow-cleaning the strap drive and strap reservoir drive, do not expose the sealing discs of the ball bearing to direct air jet. The same applies to the solenoid in the reservoir.

## **8. TROUBLESHOOTING**

### **8.1 SUGGESTED MAINTENANCE**

Fromm Packaging Australia recommends servicing every six months as a minimum, but many machines have different service intervals depending on condition and throughput. It's best to discuss your servicing requirements with Fromm Packaging.

### **8.2 WARRANTY PERIODS**

To provide you with peace of mind all Fromm stretch wrapping, strapping and carton taping equipment includes a two year warranty from the date of delivery to your site. The warranty includes all deficiencies clearly resulting from poor manufacturing or faulty materials. Damage claims as a result of production shutdowns and claims for damage to persons and to property resulting from warranty deficiencies covering structural components and non-wearing parts effective from the date of delivery to your site.

The warranty excludes:

- Wearing parts (rollers, motors and belts),
- Deficiencies resulting from improper installing, incorrect handling and maintain the equipment,
- Disregard of directions in the operation manual,
- Unauthorised repair work to the equipment,
- Use of consumable products not recommended by the supplier of the equipment.

We reserve the right to modify the product any time in order to improve the quality.

### **8.3 FROMM PACKAGING AUSTRALIA SERVICE TECHNICIANS**

Fromm service technicians are trained to service all stretch wrapping, strapping and carton taping machines which we sell and are your on-site expert support to optimise the performance and reliability of your packaging equipment.

With technical offices in Sydney, Brisbane and Melbourne metro areas we are on hand to ensure your equipment is running smoothly. Customers located outside metropolitan areas we offer phone support and can organise onsite technical support when required.

## 8.4 Possible troubleshooting Causes and Remedies

Failure/Message	Cause	Remedy
"i3" (Message at display)	No strap	(Start button / foot switch)
"i4" (Message at display)	Door or table top is open	Close door or table top
"i5" (Message at display)	Coil empty / ready to start threading	Strap thread as described in 6.2
"C2" (Message at display)	Feeding time strap reservoir exceeded	Check if reservoir lever is free-moving (contact service staff)
"C3" (Message at display)	Main Motor M1 defective Sensor B61 or B62 defective or loose. Fuse is defective	Contact service staff
"C4" (Message at display)	Feeding Motor M2 defective	Contact service staff
"C5" (Message at display)	Tensioning motor M3 defective	Contact service staff
"CU" (Message at display)	Fuse at tensioning motor M3 is defective (no signal)	Contact service staff
"CC" (Message at display)	Warning – heating up / heat-cleaning process	Terminate menu point "CC".
"CF" (Message at display)	Strap not detected after threading	Repeat threading procedure as described in 6.2.
"CH" (Message at display)	Strap fault / feeding fault	Repeat strap feeding procedure.
	Pressure plate switch cannot move easily.	Contact service staff
"Uf" (Message at display)	Failure at ultrasonic	Contact service staff
Strap is not sealed properly or sealing splits open	Heater plate is dirty.	Carefully clean heater plate at both sides, using fine abrasive paper.
	Incorrect adjustment at heater plate.	Contact service staff
	Incorrect value for heater plate temperature.	Screws at electric terminal are loose => tighten screws.
		Increase heater plate temperature (see

		chapter 5.5.2); check temperature again before you resume operation
Strap is not injected completely.	Incorrect threading of strap.	Remove strap. Cut off thoroughly with straight edge. Thread again as described in chapter 6.2.
	Strap track is blocked.	Open strap track using the lever (see Fig. 3), clean strap track. Check and clean upper strap guide using a cut-off piece of strap.
	Strap flaps are not overlapping correctly.	Check strap flaps and correct overlapping.
Strap pops out of strap arch during feeding process.	Strap flaps are not overlapping correctly.	Check strap flaps and correct overlapping.
Strap cannot be moved any more. Strap folding up between tension rollers and feed rollers (see Fig. 2).	Strap rests in strap track.	Open table top Open DAT lever (see Fig. 3) Cut off strap between tension rollers and feed rollers. Make sure not to cut the strap end too far down. Ensure that it does not get stuck! Close DAT lever. Verify that the strap can be moved and that it is not stuck. If strap cannot be moved, repeat steps 2 – 4. Close table top. Press foot switch If automatic repair attempt was successful, put machine back into operation. If not, repeat procedure starting with step 1, paying special attention to the strap end.
No activity after switching machine on	Insufficient power supply	Check power supply Insert plug, if necessary. Replace fuses.

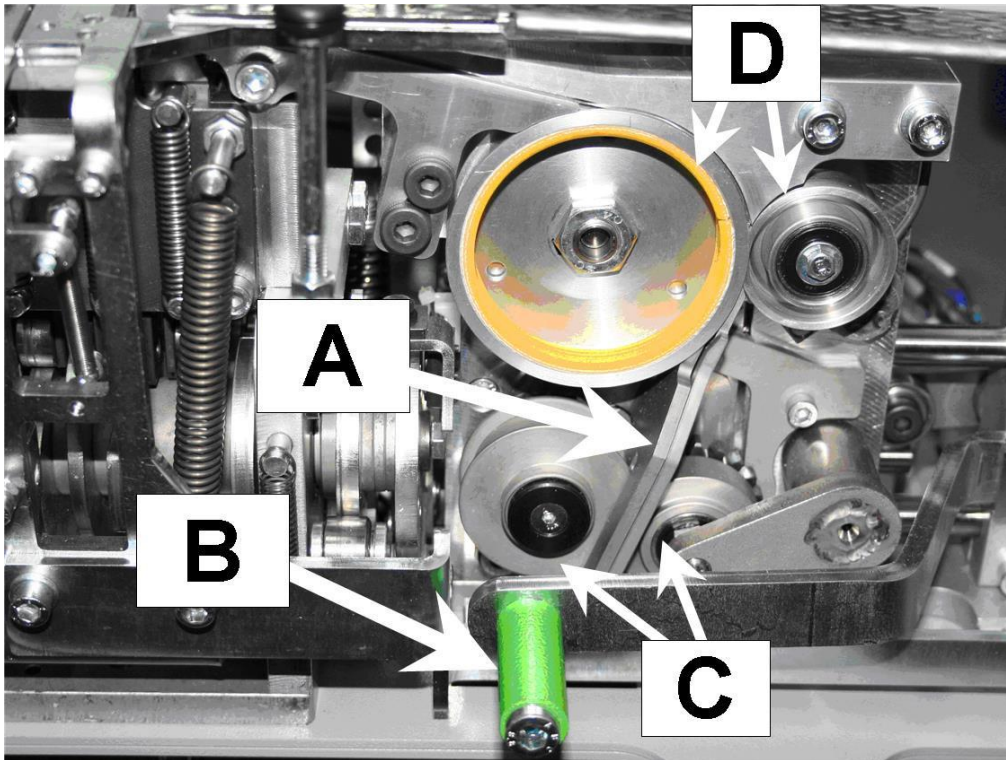

Fig. 2 Strap drive with strap track closed (A), lever (B), tensioning rollers (C), feed roller and pressure roller (D).

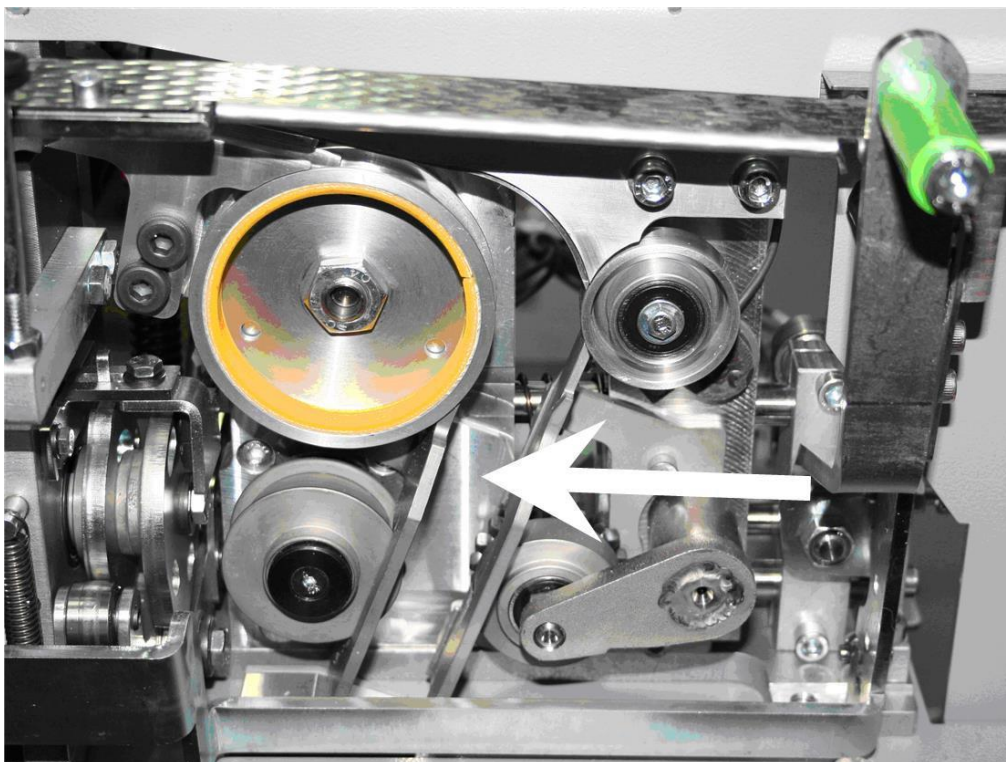

Fig 3. Strap drive with opened lever and strap track accessible. In this position, strap jams can be removed. Cut off the strap at marked area (arrow) for this purpose.

## **9. CONTACT FROMM PACKAGING AUSTRALIA**

For any questions please contact Fromm Packaging Australia

**Phone: 1800 023 890**

**Email: [info@fromm-pack.com.au](mailto:info@fromm-pack.com.au)**

**Postal Address: PO Box 4016, Mt Ommaney QLD 4074**