

FCE 2000

AUTOMATIC CARTON ERECTOR
for Medium Cartons

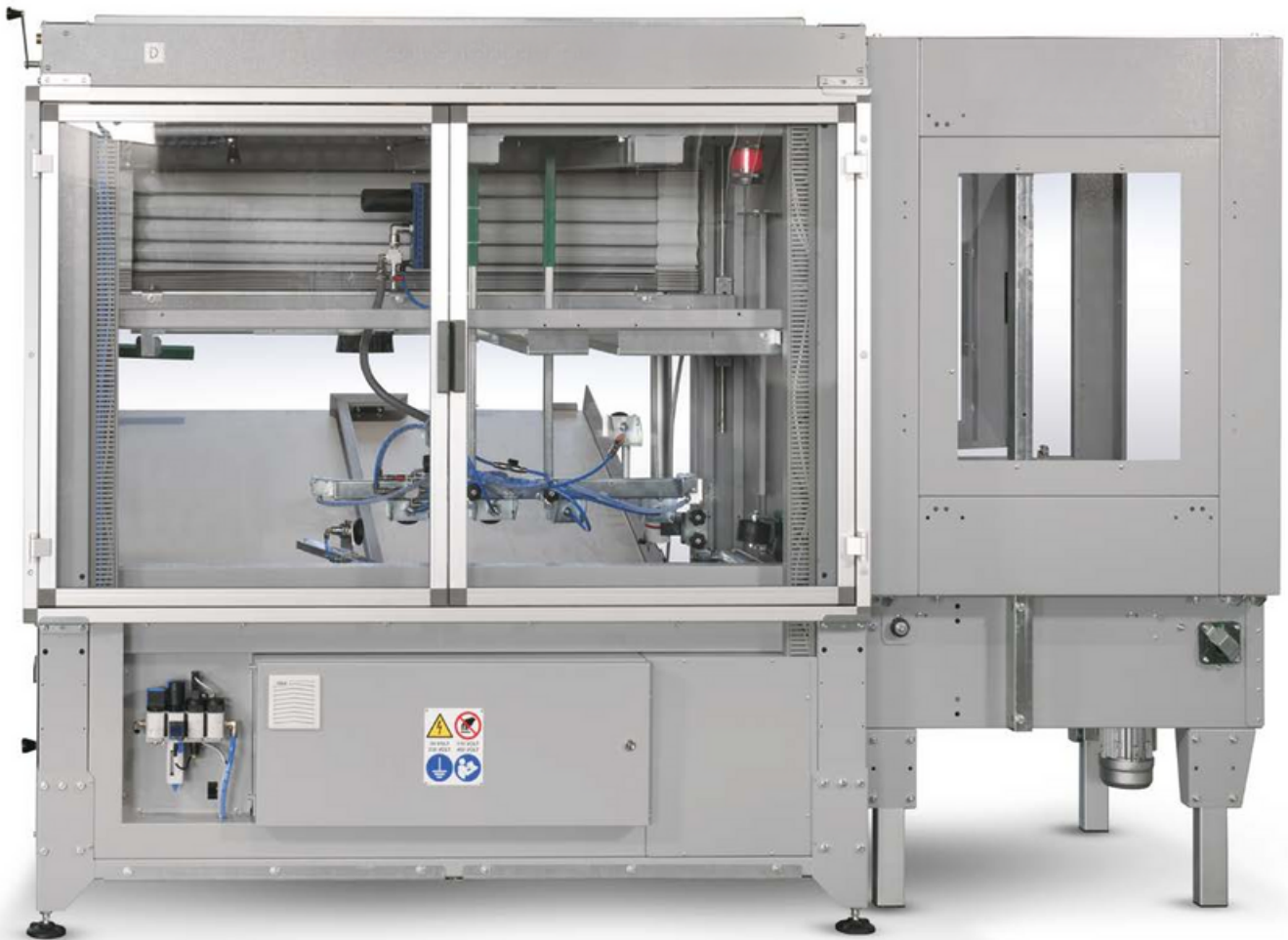

Efficient, durable and versatile

The FCE 2000 carton erecting machine builds and bottom seals empty cartons, before sending them to the packing station.

Capable of building up to 840 boxes an hour.

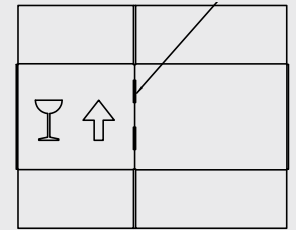
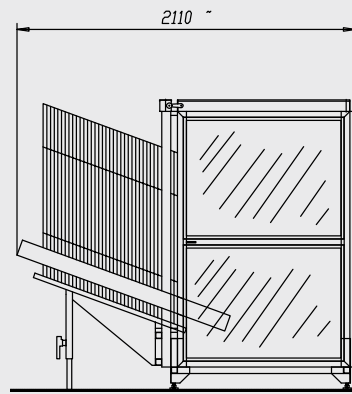
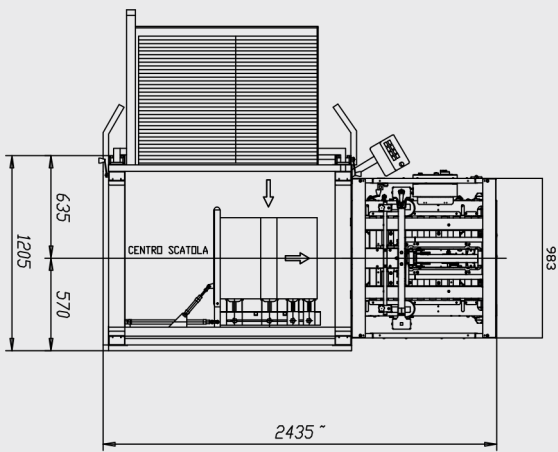

F2000 STANDARD

CARTON DIMENSIONS

LENGTH: 220mm - 600mm

WIDTH: 100mm - 500mm

HEIGHT: 100mm - 500mm

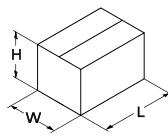

PRODUCTION

AVERAGE PRODUCTION: 840 boxes/hour

BOX LOADER UNIT CAPACITY: 110 boxes

OPTIONS

- Electric cabinet with Siemens PLC
- Caster wheels for minimum working table height 750mm
- Motorised box loader with capacity of 150, 220 or 270 boxes
- F2000H model for boxes high 900mm with tops flaps open
- Safety guards with access door

RECOMMENDED ADD-ON

FCS Conveyor system - free rolling conveyor belt up to 4500mm in length. Moves cartons seamlessly into the packaging station after sealing.

TECHNICAL SPECIFICATIONS

Power supply	Three phase/ single phase
Power	4Kw
Venturi vacuum unit	25m3/h 700mm HG
Maximum air pressure allowed	7 bar
Air consumption cycle box	22nl / 6 bar
Weight	490 Kg
Control panel	HMI touch screen



SEALING OPTIONS

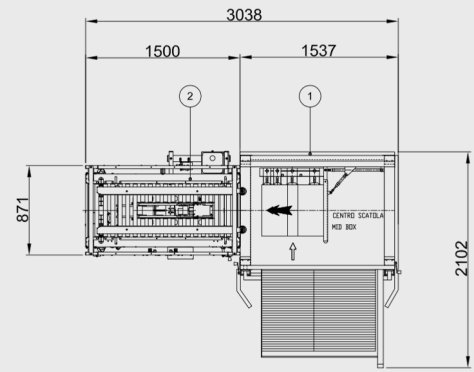

PACKAGING TAPE - FCS B52 CARTON SEALER



Capable of sealing 1000 boxes per hour, the FCS B52 carton sealer compliments and completes the work of the FCE 2000. After the carton has been built, the FCS 52 bottom seals the carton preparing it for filling.

TRANSFER SPEED: 27 metres/ minute

TAPE: Adhesive rubber or acrylic

MACHINE WEIGHT: 85Kg

WORKING HEIGHT: 650mm

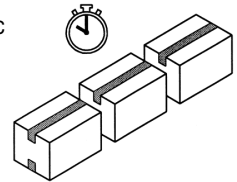

WATER ACTIVATED TAPE - FCS B520 - GP CARTON SEALER

Featuring a taping head with an autonomous water tank for normal and reinforced gummed paper tape

AVERAGE PRODUCTION: 420 boxes/hour

BOX TRANSFER SPEED: 18 metres/minute

BOX LOADER UNIT CAPACITY: 110 boxes

*When using water activated tape, technical specifications should be reaffirmed



HOT MELT - USING HOT MELT GLUE TO SEAL CARTONS

Featuring a heated glue gun, the sealer melts sticks of glue and applies them to the box flaps. The glue then cools and hardens, creating a secure seal.

*When using hot melt, technical specifications should be reaffirmed.

FROMM | PACKAGING AUSTRALIA

www.fromm-pack.com.au | 1800 940 356 | info@fromm-pack.com.au